

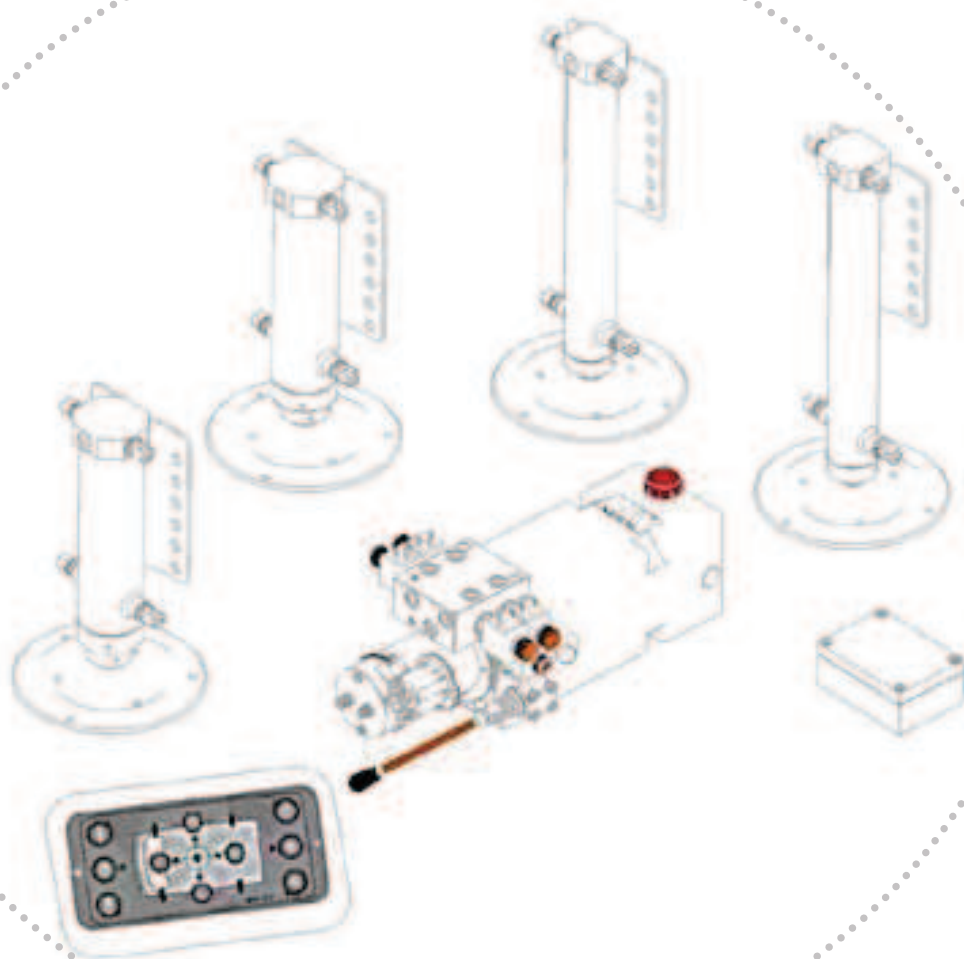

HYDRAULIC LEVELING SYSTEM



GB

D

IT

CE

INSTALLATION AND USE MANUAL
GEBRAUCHS UND INSTALLATIONSHANDBUCH
MANUALE PER L'USO E PER L'INSTALLAZIONE

TABLE OF CONTENTS

TABLE OF CONTENTS

1 - I INTRODUCTION	2
1.1 Description of the symbols used	2
1.2 Proper use	3
1.3 Description	4
1.4 Components.....	5
1.5 Technical specifications.....	5
2 -INSTALLATION.....	6
2.1 Installation of the feet.....	6
2.2 Installation of the electro-hydraulic control unit and of the electronic control box.....	7
2.3 Installation of the control panel.....	8
2.4 Electrical connections.....	9
2.5 Hydraulic connections.....	12
3 - GENERAL SAFETY REGULATIONS.....	14
3.1 Work area.....	14
3.2 Safety and electric supply	14
3.3 People's safety	14
3.4 Safety during assembly.....	15
3.5 Regulations on road circulation	15
4 USE	16
4.1 Destination of use	16
4.2 Description of the control panel.....	17
4.3 Switching the unit on and off	18
4.4 Automatic levelling cycle	19
4.5 Manual levelling cycle or movement.....	20
4.6 Return to run conditions (feet retraction)	20
4.7 Back to the customised position (S)	21
4.8 Saving the customised position (S).....	21
4.9 Feet calibration.....	22
5 – APP FOR SMARTPHONES	22
5.1 Installing the App on your smartphone and pairing the Kit	22
5.2 Moving the feet by means of the MA-VE App.....	23
6 – EMERGENCY MOVEMENTS.....	23
7 –INFORMATION.....	24
7.1 Recommendations.....	24
7.2 Alarm list and troubleshooting	25
7.3 Maintenance	26
7.4 Troubleshooting.....	27
7.5 Warranty.....	27
7.6 Disposal.....	28
7.7 Manufacturer's declaration of conformity.....	29
7.8 Warranty certificate.....	30



1 -INTRODUCTION



Congratulations on buying our new levelling system for campers. This is a technologically advanced and high quality product.

Before installing and operating the system, carefully examine the functions of the device and its proper use.

Carefully read this use manual before installing and using the system and keep it on the vehicle for quick and easy reference. If the system is transferred to a third party, do not forget to pass on all the necessary documents.

The guidelines for this MA-VE projects are easy of use and installation. Users will operate intuitive controls with efficient and comprehensible messages, both on the control panel and on the user-friendly App for smartphones. The Installer will use a ready to install kit that will make his/her work safer, cleaner and more efficient. Moreover, this kit ensures time saving operations and will relieve the Installer from needing to search useful materials for the installation. In fact, all the necessary materials are in the MA-VE kit that you have purchased.

1.1 Description of the symbols used

	Read the instructions manual		Important warning
	Keep to the safety warnings		Dispose of the system in an environmentally friendly manner
	Operations to be performed exclusively by authorised and trained personnel		See the picture concerning the letter shown



1.2 Proper use



For a proper use of your MA-VE levelling kit, carefully observe the following instructions:

- Before switching the system on, make sure that under the feet there are no obstacles that might hinder their correct opening (stones, manholes, etc.)
- Make sure that the ground where the feet will be positioned is sufficiently robust and not slippery. Otherwise, position the camper in a different place or adopt suitable measures. If necessary, you can place more supports between supporting plates and the ground.
- Do not use the system on too inclined surfaces because it cannot compensate inclinations exceeding 4°
- In case of snow or ice, remove them from the feet, plates and the ground underneath before activating the feet automatic or manual movement control
- Make sure that the batteries are always sufficiently charged; if the voltage drops below 10 Volt, the safety electronic circuit will prevent the feet from moving
- The kit must be used at external temperatures included between -20°C and +50°C. Using the kit outside this temperature range may cause damages and malfunction
- Before driving the camper, make sure that all the feet are completely retracted. In any case, do not move until the control panel LED informs you of the completion of the operations.
- Select a more levelled stop area and position the vehicle in a direction that allows for a more efficient stabilisation
- Always engage the parking brake
- For better safety, the system can work only when the engine is switched off
- When the levelling system is activated, no passengers are allowed to stay on the vehicle
- Make sure that there are no objects that might fall or get damaged during the stabilisation movements.
- Closed and/or blocked doors and panels
- If the motorhome is equipped with (full) air suspension, deflate the system before using the MA-VE levelling kit. This ensures a levelling from lowest position.



Failure to keep to these instructions may damage the vehicle and/or cause injuries:



- NEVER go under the camper when it is supported by the feet
- Do not use the MA-VE automatic levelling system for purposes other than those it has been designed for, i.e. vehicle levelling and stabilisation and reaching other, non-programmed positions. The system can be fitted with a safety device (OPTIONAL) on the feet, which prevents them from closing suddenly and unintentionally if a pipe breaks. Thanks to this option, you can use the kit in full safety, even when changing tires or installing snow chains.

- When the system is operating, no people or animals must be within its working radius.



- This is an electro-hydraulic system, therefore it contains fluids under pressure that are potentially dangerous if swallowed or if in contact with skin and eyes. Pay special attention when handling the system and do not carry out any maintenance operations in the system areas that are under pressure. Each maintenance operation requests an in-depth knowledge of the hydraulic system and of the calibration of the safety valves installed. Such operations must not be carried out by non qualified personnel.

- Installation and maintenance must be carried out by personnel having sufficient expertise and having been trained by MA-VE. "DIY" maintenance operations are strictly forbidden
- To avoid serious instability problems, never lift the vehicle completely from the ground, but always allow the wheels to touch the ground
- When the levelling system is used, make sure that all the feet touch the ground and that the ground is not soft before getting on the vehicle

1.3 Description

Automatic levelling kit MA-VE is an electro-hydraulic system made up of an electro-hydraulic control unit powered by 12V or 24V. The control unit electric motor activates a pump that takes the hydraulic oil from a special tank and sends it to the 4 hy

The 4 cylinders are fastened to the vehicle frame and must be selected from those available in the MA-VE catalogue, according to the model of your vehicle. Different types of cylinders are available, which feature different levels of lifting power, different overall dimensions in run position, different working ranges and different types of frame interface. All types of cylinders feature a large interface panel with the ground on their end, which prevents sinkage. The panel is strengthened by ribs, made in STAINLESS steel for a longer life and is fitted with water discharge holes. The supporting plate is fastened to the cylinder in a non stiff manner in order to ensure a correct support even on irregular surfaces.

The system is controlled by an electronic control unit that can perform manual or fully

automatic levelling cycles or other operations, such as emptying the tanks. The user interface features a simple control panel that fits easily the interior of your vehicle, without being invasive. An App for smartphones is also available, which allows for the remote control of the system, thus simplifying the operations

1.4 Components

1. Electro-hydraulic control unit
2. Pair of rear feet
3. Pair of front feet
4. Electronic control box
5. Control panel
6. Control panel RJ45 connection cable – electronic control box
7. Control unit wiring
8. Instructions manual

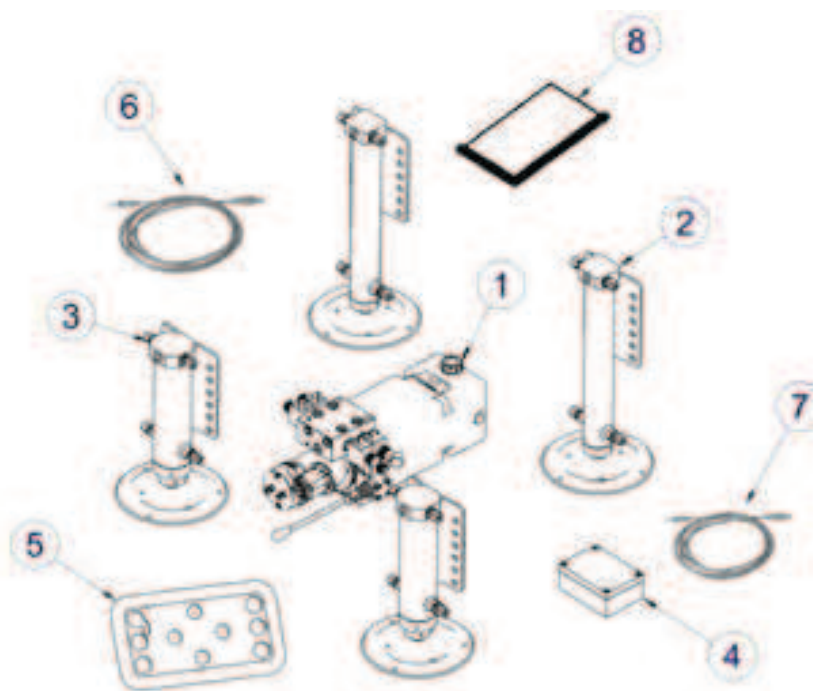

1.5 Technical specifications

- | | |
|--------------------------------------|---------------------------------------|
| • Power supply | 12V DC -10 +30% |
| • Power | 960 W |
| • Absorbed current | Max 80 Ampere |
| • Absorbed current in Stand By | < 50 mA |
| • Protection fuse | 180 A |
| • Type of hydraulic oil | ATF oil (Mobil ATF 220, for instance) |
| • Capacity of the hydraulic oil tank | 3.5 litres (standard) |

2 - INSTALLATION



The system can be installed only by specialised personnel who has been properly trained by MA-VE

A wrong installation can cause injuries and damages the vehicle and the devices.

To avoid damaging your vehicle and for a safe installation, we inform you that our levelling kits request professional Installers. Please contact our sales and service network. Excellent results and a satisfactory experience of use of the system are ensured by a professional installation and adjustment of the entire kit. The personnel we have authorised for these operations has been trained with special courses showing all technical and safety aspects concerning this product in an exhaustive manner.

A "do it yourself" installation will not ensure the same results in terms of performance and may even cause serious damages to your vehicle and serious injuries.

Before installing the kit, open the packages, check the integrity of each component and of the supplied accessories indicated in this manual.



MA-VE will not accept any claims for damages caused by transport or lacking materials signalled after the assembly of the kit.

Before assembling the kit, carefully read the safety regulations for installation. Failure to keep to the instructions may cause serious damages and injuries.

On the vehicle, find free positions where the feet, the electro-hydraulic control unit area, the electronic board and the control panel can be installed. Also find the correct path and fastening of cables and pipes.



When ordering the kit, clearly specify the model and year of manufacture of your vehicle in order to receive the correct type of feet and support.

2.1 Installation of the feet



2 pairs of feet will be supplied. They can be different from each other in terms of hydraulic cylinder type or fastening method. One of the pairs will be for the front axle of the vehicle, the other pair will be for the rear axle. The feet will be fastened only by means of the fastening brackets supplied for your vehicle and in the points indicated by your Installer. First install the fastening brackets supplied according to the features of your vehicle. Then fasten the feet to the brackets and carry out the hydraulic connections (see paragraph 2.5)



For good operation, prepare a pit or a lift with a lifting capacity that is correct for the weight of your camper.



In the kit you will find all the necessary fastening materials, such as flanges, bolts, nuts and pipes.

DO NOT USE COMPONENTS THAT ARE NOT SUPPLIED BY MA-VE

2.2 Installation of the electro-hydraulic control unit and of the electronic control box

Find a space or area in the camper that is sufficiently protected from bad weather and dirt, in a central position and on one of the two sides of the camper. If possible, select the door side and the closest one to the engine battery the system should be connected with the living room batteries.

Fasten the pre-assembled brackets to the electro-hydraulic control unit with the screws supplied. Keep to the instructions on the direction of the electronic control box indicated on its adhesive labels.

Position the control unit in a way that the activation control of the manual emergency pump and the emergency releases (orange in the picture) on the solenoid valves are at hand and within reach.

The hydraulic oil filler cap in the tank (red in the picture) must be easy to reach and its position must allow for an easy oil filling.

2.3 Installation of the control panel



Find an area that is easily accessible and visible in the camper.

It should be preferably next to the driver's seat. The cable supplied that connects the box and the panel is 10 metres long and ensures the best possible installation.

With a 15 diameter core cutter, make a through hole in the point selected for the assembly. Lead the RJ45 patch cat6 connection cable supplied with the kit inside the hole and connect the box and the internal control unit. Then fasten the internal control unit to the camper by means of the 4 screws supplied.

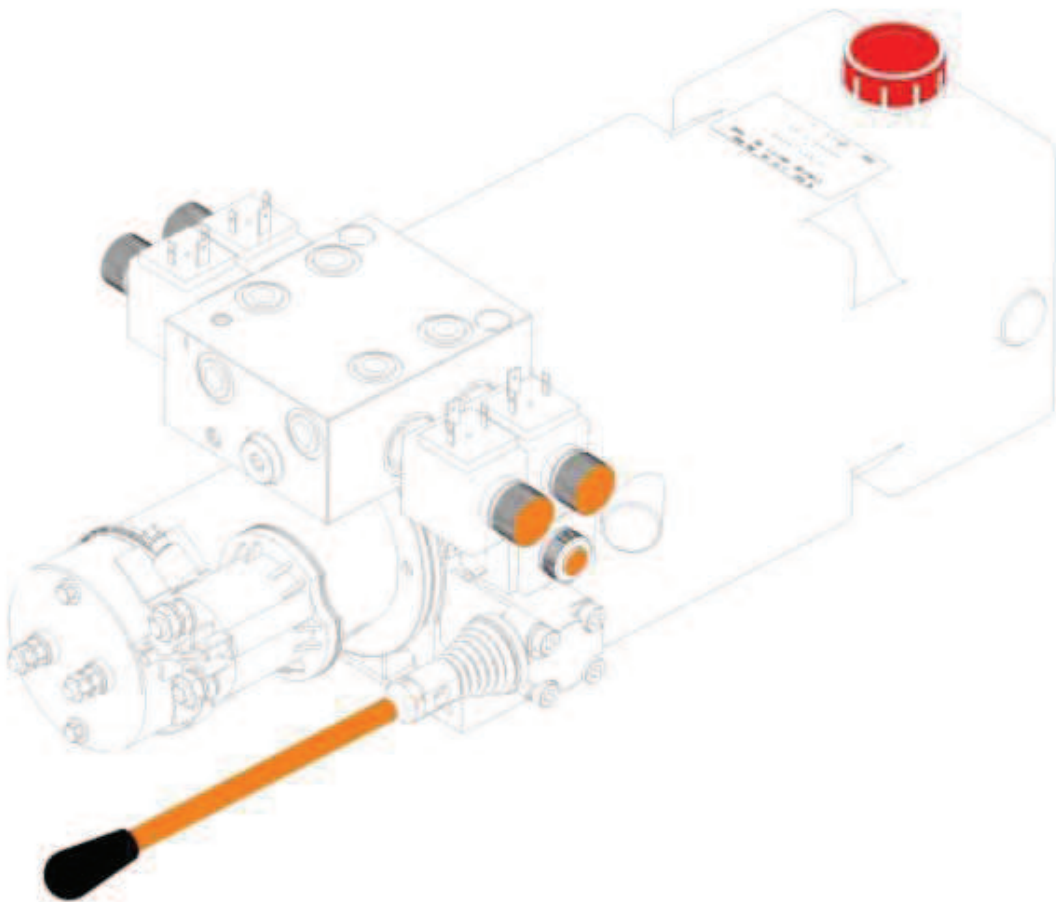

2.4 Electrical connections



Keep to the instructions of the following wiring diagram:

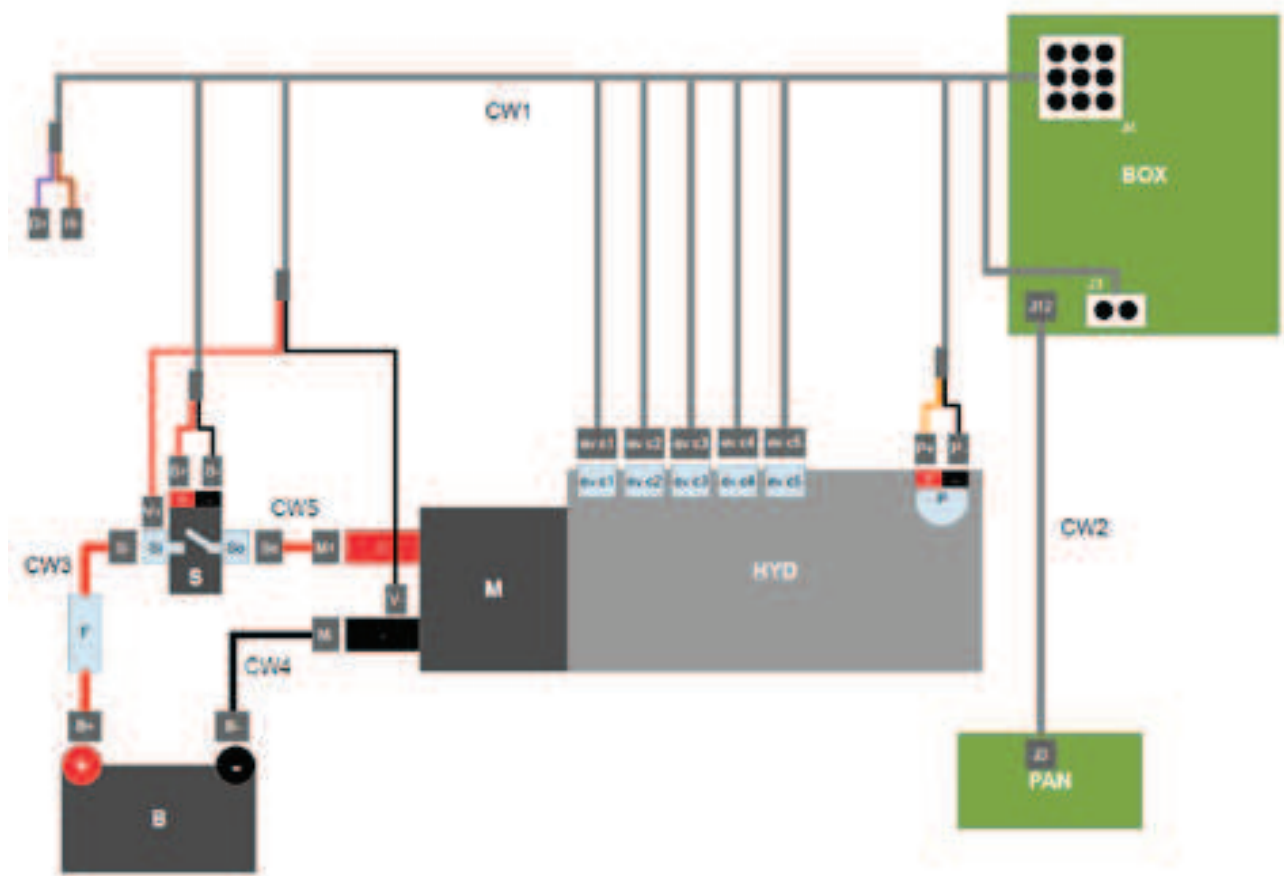

GB



SYMBOL	DESCRIPTION
B	Vehicle battery.
B-	Ring terminal of the CW4 cable for the connection to the negative terminal of the vehicle engine battery.
B+	Ring terminal of the CW3 wiring for the connection to the positive terminal of the vehicle engine battery.
BOX	Control unit electronic control board.
CW1	Wiring connecting the electronic control board (BOX), the power to the pump electric motor, the control terminals (reel) of the solenoid, the solenoid valves, the pressure switch, the ignition key and the hand brake.
CW2	Straight CAT5 Ethernet cable connecting the electronic control board, (BOX) and the control panel (PAN) electronic board. Both BOX and PAN boards must never be connected to other Ethernet devices. The only permitted connection is between the BOX and PAN boards.
CW3	Wiring with fuse for the connection of the vehicle engine battery positive terminal to the power input (Si) of the solenoid.
CW4	Cable connecting the vehicle engine battery negative terminal to the negative terminal of the pump electric motor.
CW5	Cable connecting the solenoid output power contact (So) to the positive terminal of the pump electric motor.
D+	Male Faston connector of the CW1 wiring for the ignition key.
sv C1	Solenoid valve controlling the front right stabilising piston and relevant wiring connector CW1.
sv C2	Solenoid valve controlling the front left stabilising piston and relevant wiring connector CW1.
sv C3	Solenoid valve controlling the back left stabilising piston and relevant wiring connector CW1.
sv C4	Solenoid valve controlling the back right stabilising piston and relevant wiring connector CW1.
sv C5	Solenoid valve controlling the flow direction and relevant wiring connector CW1.
F	Fuse.
H-	Male Faston connector of the CW1 wiring for the hand brake.
HYD	Electro-hydraulic unit including the pump with the oil tank, the solenoid valves and the pressure switch.



J12	Ethernet connector on the control electronic board (BOX) for the connection to the control panel electronic board (PAN) via the CW2 cable. Both BOX and PAN boards must not be connected to other Ethernet devices. The only permitted connection is between a BOX and a PAN board.
J3 in BOX board	Two pole connector on the electronic control box (BOX) connecting the ignition key and the hand brake via the CW1 wiring.
J3 in PAN board	Ethernet connector on the control panel electronic board (PAN) connecting to the electronic control box (BOX) via the CW2 cable. Both BOX and PAN boards must not be connected to other Ethernet devices. The only permitted connection is between a BOX and a PAN board.
J4	Nine pole connector on the control electronic board (BOX) connecting the power supply, the solenoid control terminals (reel), the solenoid valves and the pressure switch via the CW1 cable.
M	DC electric motor of the electro-hydraulic unit HYD pump.
M-	Ring terminal of the CW4 cable connecting to the negative contact of the pump electric motor.
M+	Ring terminal of the CW5 cable connecting to the positive contact of the pump electric motor.
P	Pressure switch.
P-	Female Faston connector of the CW1 wiring connecting the pressure switch negative contact.
P+	Female Faston connector of the CW1 wiring connecting the pressure switch positive contact.
PAN	Control panel electronic board.
S	Solenoid for the isolation of the vehicle engine battery positive pole after the fuse.
S-	Female Faston connector connecting the solenoid control negative terminal (reel).
S+	Female Faston connector connecting solenoid control positive terminal (reel).
Si	Input power contact of the solenoid and relevant ring terminal of the CW3 wiring.
So	Output power contact of the solenoid and relevant ring terminal of the CW5 wiring.
V-	CW1 wiring ring terminal connecting the pump electric motor negative contact.
V+	CW1 wiring ring terminal connecting the solenoid input power contact (Si).



Connect the two control unit connectors to the electronic control box.

Take the electric power from the engine battery.

Connect the hand brake ON contact

Connect the special power cable to the vehicle start console in order to allow for the automatic retraction of the feet when the previously levelled vehicle is started. The D+ enabling signal is often on pin 15 of the main terminal board and in any case it corresponds to a positive voltage of +12 VDC generated when the vehicle ignition key is switched on.

2.5 Hydraulic connections

Keep to the following instructions to carry out the hydraulic connections and use the pipes supplied by MA-VE.

The following instruction is particularly important:

Connect the position indicated with C1 to the opening arm of the right front foot

Connect the position indicated with C2 to the opening arm of the left front foot

Connect the position indicated with C3 to the opening arm of the right back foot

Connect the position indicated with C4 to the opening arm of the left back foot

Connect the position indicated with R1 to the pipe from the closing arm of the back pair of feet

Connect the R2 position to the pipe from the closing arm of the front pair of feet

Make sure to carefully tighten each fitting in order to avoid oil leakages from the system. Carry out the connections in a clean environment in order to avoid contaminations that might deteriorate the components. Fasten the pipes with straps along the path from the foot to the control unit in order to prevent them. Use protection tubes under the straps and there where you go through frame holes to avoid chafe marks on the pipes from hanging from the vehicle bottom.



After carrying out all the connections and filling the hydraulic oil tank, carry out a few manual movements of the feet until they are totally extended in order to remove all the air from the system.

In case of air in the cylinders and in the pipes, the stability of the camper when parked might be compromised.

Type 1



Available in the lengths:
3 m – 3.5 m – 4 m – 4.5 m – 5 m – 5.5 m

Type 2



Available in the lengths:
2 m – 3.5 m – 3 m

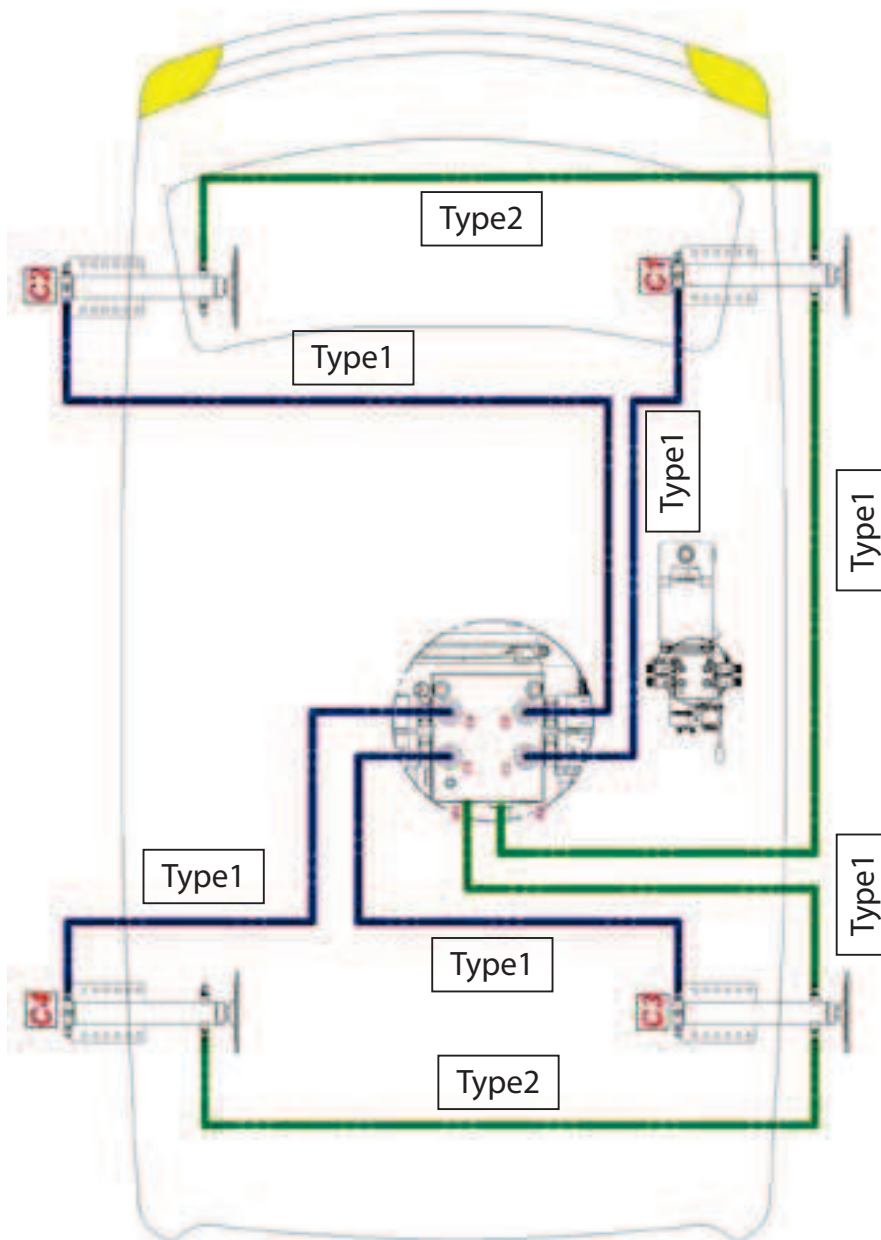

3 - GENERAL SAFETY REGULATIONS



WARNING! Read all the instructions.

Failure to keep to the following instructions may cause serious damages and injuries

KEEP THESE INSTRUCTIONS

3.1 Work area



Before enabling the feet automatic or manual operation control, make sure that: The feet working area is free from obstacles (stones, ground hollows, mud, ice, etc.)

RISK OF DAMAGING THE KIT AND THE CAMPER.

3.2 Safety and electric supply

The unit must be powered exclusively with 12 Volt, directly from the engine battery, with cables having a section that is suitable to the distance between the battery and the control unit, according to the following table:

Battery / Box distance	Cable section
< 3m	25 mm ²
>3m < 6m	35 mm ²
> 6m > 10m	50 mm ²

If 12 V electric power supply units are used in place of the battery, make sure that they are stabilised and with an output capacity of 3 Amp without interruption and of 10 Amp for short periods. Non stabilised and poor quality battery chargers must be absolutely avoided.

3.3 Safety of persons



Before enabling the feet automatic or manual operation control, make sure that nobody is under the camper for maintenance or inspections. If someone is under the camper, he/she could be in the radius of action of the feet when they are opened and retracted.

RISK OF SERIOUS INJURY.

The device contains liquids under pressure! Do not tamper with the pipes and do not operate on the fittings and other parts of the hydraulic circuit.
RISK OF SERIOUS INJURY.



3.4 Safety during assembly

For the assembly operations that request the presence of an operator under the camper, the necessary safety precautions must be adopted, such as the use of a lifting bridge complying with the safety regulations in force or a workshop floor with the special pit for the operator and a sliding platform used to access the area under the camper in a lying position.

During the assembly operations, make sure that:

- the unit is switched off from the electric power mains
- the operator in charge of assembly does not suffer from claustrophobia, as he/she will have to work under the vehicle and in narrow and very small spaces
- the person in charge of assembly wears non-slip and accident-prevention shoes
- during assembly, nobody is in the working radius of the feet
- the lifting equipment is non-slip and dry
- the bridge and ladder are sufficiently stable and robust

3.5 Regulations on road circulation:

If the feet do not protrude laterally from the vehicle outline, no notification on the road traffic papers is necessary.



4 USE

4.1 Destination of use

The levelling kit has been designed and manufactured to be used in the parking areas in order to make your stay safer and more pleasant.

Thanks to the MA-VE electro-hydraulic levelling system, your vehicle will be automatically levelled and more stable by simply pressing a button.

You will be able to walk on a solid floor without swinging. The wind will not disturb you and your privacy will be protected as the doors will stay closed. This kit ensures a smooth and flawless operation of the washbasin and shower drains and the same comfort as if you were at home.

Ease of use and of installation are the most important factors of this MA-VE product. The User will use intuitive controls and efficient and easily comprehensible warnings from the control panel and from the functional App for smartphones. The Installer will have a ready-to-install kit with special features that make his/her work cleaner, safer and time saving. Moreover, the Installer is relieved from needing to search useful materials for the installation. In fact, all the necessary materials are in the MA-VE kit that you have purchased.

The kit can be used only in the modes and for the purposes indicated in this manual. Any different use will invalidate the warranty.



WARNING: we do not accept any responsibility for any damage caused by:



- Wrong and improper use of the kit, other than its intended use
- Repairs carried out by non authorised service centres
- Tampering with any kit component
- Use of non original spare parts
- Failure to keep to the use instructions in this manual.

THE WARRANTY WILL BE INVALIDATED IN THE ABOVE-MENTIONED CASES

4.2 Description of the control panel

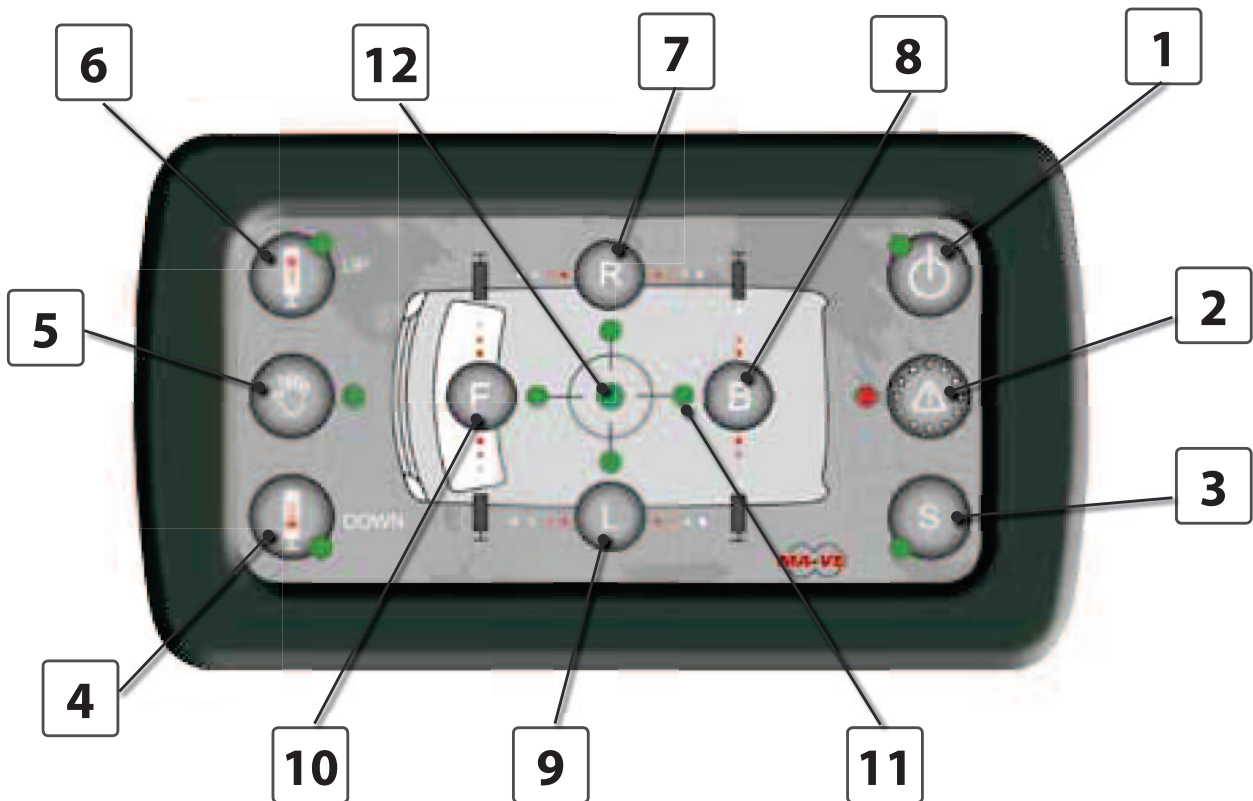

This figure indicates:

1. System ON/OFF button and LED
2. Alarm buzzer and LED
3. Special position recall button and LED
4. Feet automatic lowering button and LED for automatic levelling
5. Manual and semi-automatic control enabling button and LED
6. Automatic retraction button and LED for all the feet
7. RIGHT side feet pair manual movement button
8. BACK side feet pair manual movement button
9. LEFT side feet pair manual movement button
10. FRONT side feet pair manual movement button
11. 4 PAIR LEDs indicating the feet in movement or to be moved
12. BUBBLE LEVEL LED



4.3 Switching the unit on and off

When the ON/OFF (1) button is pressed, all the control panel LEDs will turn on for a while in order to check their correct operation. After 2 seconds, they all turn off, except for the ON/OFF (1) button and the other buttons that show the system status.

If the ON button is switched on, the basic functions, such as automatic levelling, manual levelling and tank discharge, can be performed by pressing the relevant button, after reading the instructions in the relevant paragraph.

If the system has retracted feet, the LED of the last button that has generated the feet movement (DOWN (4), MANUAL (5) or S (3)) will be on with a steady light, followed by the steady light of the BUBBLE LEVEL LED (12) if the camper is levelled; otherwise the BUBBLE LEVEL LED (12) will be flashing and the PAIR LED (11) will be on with a steady light to indicate the direction of the camper inclination.

In this condition the User can press the feet UP button (6) to retract the feet in order to be in start condition or can change the camper tilt by pressing the automatic levelling DOWN (4) button to restart a levelling cycle (if the previous levelling has been lost because the camper is parked on a soft ground); the User can also carry out manual movements by enabling the special controls by pressing first the MANUAL button (5) and then the FRLB buttons (7)(8)(9)(10).

Whenever a button is pressed, which changes the camper trim, the system checks certain prerequisites, which, if not present, generate an alarm signal. For instance, the cylinder descent movements are enabled only if the hand brake is activated, the engine is off and the battery charge is sufficient. If these prerequisites are not present, the ALARM LED (2) will turn on, followed by the BUZZER or voice note signalling the type of alarm occurred. Refer to the ALARM section for more details.

These prerequisites must be checked when the User presses a button on the control panel and must be MAINTAINED as long as the feet are not in rest position. If someone seats on the driver's seat and disengages the hand brake, the BUZZER (2) will give an alarm signal and the LED will flash. If the camper is started, the return cycle of the feet to their start position will start automatically, the BUZZER (2) will sound intermittently and its LED (2) will signal the relevant alarm code.

Press the On/Off button (1) to stop the system. The system will switch off automatically to save the battery charge if no operation is performed for a few minutes.



4.4 Automatic levelling cycle

Press the ON/OFF button (1) and wait until the status of the system has been verified and signalled as outlined in the specific paragraph (ON/OFF LED (1) is on)

Press the feet DOWN button (4). The system checks if all prerequisites are met and starts the automatic levelling cycle. The DOWN button LED (4) is on and steady, while the BUBBLE LEVEL LED (12) will blink until the levelling is completed. At the same time, the PAIR LEDs (11), indicating the pair of cylinders the system is moving, will start blinking in order to make the User understand how the system works.

Once the levelling is completed, the BUBBLE LEVEL LED (12) will become steady like the button (4).

If the system is not able to level because of an excessive inclination, it will immediately signal an error before starting the levelling process. The User can therefore add some wedges under the feet facing downhill in order to increase their slide stroke. Pressing the DOWN button (4) again, the feet will try to level once more.

The User can now check whether the position reached is acceptable or not. If not, the User will have to press the UP button (6) to return to stop position and to add more wedges under the feet indicated by the bubble level LED.

If one or more feet sink into soft ground, the control unit will detect an unexpected movement and will stop the levelling cycle. Once again, adding some wedges can help to increase the supporting surface and reduce the sinking.

Once the levelling is completed and the BUBBLE LEVEL LED (12) is on and steady, the User can turn the system off by pressing the ON/OFF button (1)



4.5 Manual levelling cycle or movement

Press the ON/OFF button (1) and wait until the status of the system has been verified and signalled as outlined in the specific paragraph.

Press the manual control button (5) enabling a semi-automatic levelling process or the manual movement of the pairs of cylinders.

By pressing this button, the corresponding LED (5) is switched on and indicates that the manual controls, that is to say the 4 buttons FRLB (7)(8)(9)(10), are enabled. The system, by means of the PAIR LEDs (11), will suggest which buttons must be pressed in order to level the vehicle. The PAIR LED (11) corresponding to the most inclined side and the OK LED (12) will start to blink at the same time. Press and hold the corresponding button to make the 2 feet move. Release the button to stop the movement and make the PAIR LEDs (11) suggest the following operation. On the other hand, if the User keeps holding the button, the BUZZER (2) will emit a beep as soon as that side's inclination is not predominant any more, indicating that the side levelling has almost been reached. At this point, releasing the button, a blinking LED will suggest which pair of feet must be moved. Once the levelling is completed, the BUBBLE LEVEL LED (12) will be on and steady. If the levelling cannot be completed, an alarm similar to the one described in the automatic procedure will occur. By following the indications of the bubble level LEDs, the User will be guided through a semi-automatic levelling procedure. On the other hand, by ignoring the suggestions of the PAIR LEDs (11), the User will only obtain a manual movement not aiming at levelling the vehicle and the PAIR LEDs (11) will only give the User an indication of the inclination direction.

Once the desired position has been reached, the User can turn the system off by pressing the ON/OFF button (1)

4.6 Return to run conditions (feet retraction)

If the feet need to be retracted so that the vehicle can return to run conditions, turn the system on (if it is off) by pressing the ON/OFF button (1) and wait until the status of the system has been verified and signalled as outlined in the specific paragraph.

At this point, just press the UP button (6) so that the system can automatically start a procedure to make all 4 feet return to stop position. The 4 feet will be closed simultaneously. Therefore, by pressing the UP button (4), the corresponding LED (4) will start to blink and will become steady only when the return operation is completed.



4.7 Back to the customised position (S)

Press the ON/OFF button (1) and wait until the status of the system has been verified and signalled as outlined in the specific paragraph.

Press the S button (3) in order to make the camper reach a previously saved position. Such position will ease tank emptying or other repetitive operations. As tanks are usually located on either side of the camper, by pressing the S button (3) one side of the camper will be lifted and inclined towards the opposite direction.

Press the S button (3). The system checks if all prerequisites are met and starts the cycle allowing to go back to the previously saved position. If there is no saved position, an ALARM signal (2) will be emitted. On the other hand, if a position has been saved, the S button LED (3) will become steady, while the LED corresponding to the moving pair of feet will start to blink. Once the operation is completed, the LED will stop blinking and will become steady.

In order to return to run conditions, just press the UP button (6) to enable the feet closing cycle.

Once the desired operations are completed, the User can turn the system off by pressing the ON/OFF button (1)

4.8 Saving the customised position (S)

Press the ON/OFF button (1) and wait until the status of the system has been verified and signalled as outlined in the specific paragraph.

In order to programme the S button (3), hold the S button (3) for 5 seconds. At this point, the LEDs corresponding to the FRLB buttons will start to blink simultaneously, while the LED next to the S button (3) will remain steady. In order to conclude the operation, press one of the FRLB buttons (7)(8)(9)(10) – the one corresponding to the pair of cylinders that have to be completely extended when using the S function. Hold the S button for 5 seconds again to save the operation. When the S button is off, the programming is completed and the position is saved and ready to be retrieved by pressing S (3). The BUZZER (2) will emit a feedback confirming the successful completion of the programming

4.9 Feet calibration



This operation must be performed exclusively by trained personnel on a level and firm ground. This operation must be performed by the Installer and the User is not allowed to modify it.

If it is necessary to modify the target position, contact the Installer or the MA-VE service network that will repeat the system calibration.

The following calibration procedure must be performed after the installation of the levelling system and parking the camper on a level ground.

Press the UP and DOWN buttons simultaneously until the corresponding UP and DOWN LEDs are switched on and hold the buttons for at least 5 seconds until the buzzer emits a beep.

When the buzzer emits the beep, the calibration will start.

During calibration, the following LEDs will be steady: UP, MANUAL, DOWN, ON/OFF, ALARM, S; on the other hand, the following LEDs will blink: F, R, L, B and OK.

The calibration is completed when the buzzer emits another beep and the UP and DOWN LEDs are switched off.

5 – APP FOR SMARTPHONES

5.1 Installing the App on your smartphone and pairing the Kit

The MA-VE application is available both for iPhone and Android smartphones. Just download it from the App Store, Google Play or directly from the website www.ma-ve.com and install it on your smartphone.

Once installed, open the application and follow the instructions on the display to pair your smartphone and the levelling kit installed on your camper.

The pairing is performed via Bluetooth and allows an area of action of 20metres.

The device, smartphone or tablet, and the levelling kit can be paired by means of a protected authentication procedure inside the app.

The pairing is therefore univocal in order to avoid any interference with other vehicles equipped with the MA-VE kit parked in the nearby.

This univocal pairing also ensures the security needed.

The pairing only needs to be performed once. Afterwards, the control panel will be ready to be used after starting the app.

5.2 Moving the feet by means of the MA-VE App

After pairing the devices and whenever the MA-VE App is started, the display will show a reproduction of the control panel described in paragraph 4.2.

The operation of the different movements is therefore similar to the instructions given for the control panel. However, the User can benefit from the possibility of walking outside the camper to monitor the levelling operations.

In case of alarm or status signals, the app will give the User more details than the control panel installed on the camper, for instance:

- system status with a more detailed indication of the current operation (not only LEDs switched on/off)
- system alarm signal with a screen summarising the operations needed in order to solve the error
- transverse inclination in °
- longitudinal inclination in °
- battery voltage value in V
- estimated extension for each foot in mm

6 – EMERGENCY MOVEMENTS

In case of vehicle breakdown due to dead batteries or in case of malfunction of the kit's electro-hydraulic control unit, a manual procedure is available to move the feet:

Open the compartment where the electro-hydraulic control unit has been installed

Identify the 4 solenoid valves that monitor respectively the 4 feet (in the above figure, the valves are highlighted in orange). The solenoid valves are near the pipes that bring the oil to the feet and are marked by C1, C2 C3 and C4 Identify the exchange solenoid valve that allows the swap between the opening and the closing of the feet (in the figure, this valve is highlighted in purple).

Manually move the emergency control of the exchange valve to direct the oil towards the opening or the closing side of the feet. More specifically, the unscrewed ring nut allows the solenoid valve to direct the oil towards the feet opening side. On the other hand, by screwing the ring nut the User can manually close the feet in order to return to run conditions.

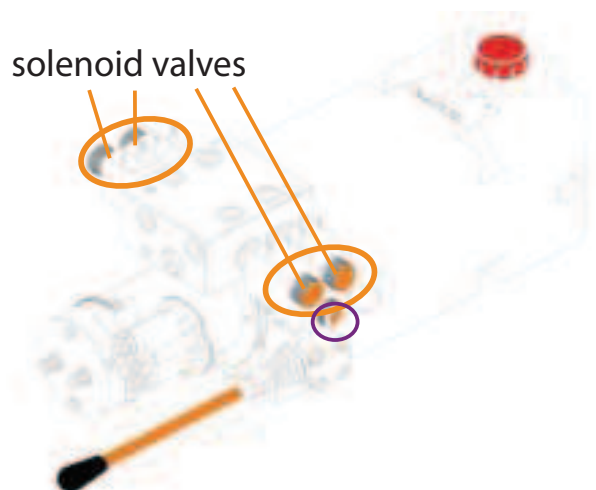



To close the feet, also screw the emergency ring nuts placed on the solenoid valves corresponding to the cylinders that the User wants to move. If the vehicle has to return to run conditions, the User usually has to screw the ring nuts located on the 4 solenoid valves in order to allow the closing of all the feet.

If not yet done, screw the lever on the emergency manual pump and start pumping. A few minutes will be sufficient to reach the desired position or to return to run conditions.



Once the desired position has been reached, unscrew the specific ring nuts to make all the solenoid valves return to their automatic control positions. Be careful when bringing the system back to its automatic operation – unscrew all the ring nuts that have been manually moved. Failure to do so may cause some system anomalies during the automatic movements performed afterwards.

7 – INFORMATION

7.1 Recommendations

To protect your automatic levelling kit and ensure its longer life and utmost efficiency, respect the following recommendations:

- Do not use the system if the battery is not sufficiently charged
- Do not use the system on a soft ground
- Do not use the system on too inclined surfaces, because it cannot compensate inclinations exceeding 4°
- To avoid any overheating and damage of the electric motor, do not use the system under constant stress for more than 5 minutes

CAUTION: we do not accept any liability for damage caused by:

- wrong use that does not comply with the intended use of the device
- repairs not performed by authorised service centres
- tampering with any component
- use of non-original spare parts and fittings
- non-observance of the instructions in this manual

IN THE ABOVE-MENTIONED CASES THE WARRANTY IS VOID



7.2 Alarm list and troubleshooting

The alarms are managed through light impulses emitted by the red alarm LED and acoustic warning signal sequences. When a functional error occurs, a series of flashings and acoustic signals will indicate which kind of error is underway. To find out what kind of error has occurred, just press the ON/OFF button.

The kind of error is described in the table below:

Alarm type	Alarm description	Description	Solution
1 flash with 1 beep	Warning: S function not saved	The side on which the User wants to completely extend the feet has not been saved	Save the side through the specific procedure
2 flashes with 2 beeps	Warning: levelling not possible – automatic mode	The inclination exceeds the one reachable when the feet are fully extended	Add some wedges. By pressing the down button, the system will perform the levelling in so far as it can.
3 flashes with 3 beeps	Warning: levelling not possible – manual mode	The inclination exceeds the one reachable when the feet are fully extended	Add some wedges. The system will perform the levelling in so far as it can.
4 flashes with 4 beeps	Key alarm	The key has been inserted in the dashboard	Remove the key from the dashboard. Wait until the feet are fully retracted.
5 flashes with 5 beeps	Parking brake alarm	The parking brake is not engaged	Engage the parking brake in order to continue the operations.
6 flashes with 6 beeps	Battery voltage alarm	The battery voltage is low	Switch the vehicle on to charge the battery. Replace the battery.
7 flashes with 7 beeps	Warning: feet retraction timeout	The feet retraction has been lasting too much and the pressure switch signal could not be detected	Press the UP button to control the feet retraction. Retract the feet through the manual lever. Check if the cables of the pressure switch are connected. Contact the customer service.
8 flashes with 8 beeps	Warning: feet descent timeout	The feet descent has been lasting too much	Press the UP button to control the feet retraction. Retract the feet through the manual lever. Contact the customer service.



9 flashes with 9 beeps	Warning: feet descent timeout during the S operation	The feet descent has been lasting too much	Press the UP button to control the feet retraction. Retract the feet through the manual lever. Contact the customer service.
10 flashes with 10 beeps	Fully extended feet alarm	During the levelling operation, the feet have reached their maximum extension	Press the UP button to control the feet retraction. Add some wedges. Repeat the levelling operation
11 flashes with 11 beeps	Warning: levelling loss	Once the levelling is completed, the system signals a levelling loss	Repeat the automatic levelling operation or perform the manual levelling
12 flashes with 12 beeps	Actuators alarm	The alarm occurs if the system does not detect the activity of one or more actuators when moving the feet.	Retract the feet through the manual lever. Contact the customer service

7.3 Maintenance

The system does not require any particular maintenance operations. Therefore, if the kit's components are removed or tampered with, the warranty covering the kit will be void.

Periodically check the oil level in the tank and, if needed, fill up with some hydraulic oil, as stated on the label applied on the tank. Always check the level and fill the tank up with the feet fully retracted and in the run position.

Change the fluid every 2/3 years. Contact your authorised MA-VE Installer.

Periodically check the electrical connections.

Remove dirt from the feet

If the feet are down for extended periods in salty environments, spray the rods every 15 days with a silicone lubricant or perform a closing and opening cycle of the feet.

In case of FAILURE, have the equipment repaired exclusively by qualified and authorised personnel (see paragraph 7.6 concerning service centres). This guarantees that the equipment is used in safety conditions, without running the risk of voiding the warranty, and that only original spare parts are used.



7.4 Troubleshooting

Problems	Cause	
The feet do not move	<ul style="list-style-type: none"> • No power supply • No oil • The camper is switched on • The parking brake is not engaged • Loose or broken connection 	<ul style="list-style-type: none"> • Switch the control panel on • Check the battery status • Fill up the oil level • Switch off the camper • Engage the parking brake • Check the connections
The system is not able to level	<ul style="list-style-type: none"> • The vehicle is parked on a too inclined surface • Soft ground 	<ul style="list-style-type: none"> • Choose a different area or another orientation • Move the vehicle or increase the supporting surface
The system emits an alarm signal	-	<ul style="list-style-type: none"> • See paragraph 7.2

7.5 Warranty

The equipment has a warranty of 3 years from the date of purchase for all its mechanical parts and of 2 years for the electronic parts.

MA-VE warrants that the equipment has been manufactured and tested carefully and is therefore free from defects before its delivery.

Keep the receipt or invoice, which must be shown as a purchase proof for any service operations under warranty (otherwise, the warranty is void)

We will repair any defects found on this equipment free of charge in a reasonable time after receiving the equipment.

The necessary costs for this purpose, especially the work and material costs, will be totally charged to us, while the costs and risks concerning the transport of the equipment to the authorised centre will be charged to the User.

The operations under warranty do not imply an extension or renewal of the warranty period of the equipment.

The replaced parts automatically become our property.

For any warranty operations, we kindly ask the User to deliver the equipment to our authorised service centre.



Make sure that the packaging is in perfect conditions for a safe transport (original packaging).

A brief description of the failure must be included and inserted in the pack, together with the User's full address. Moreover, as a proof of warranty right, do not forget to put the original document of purchase (receipt or invoice) in the pack.

WAIVERS

The warranty does not cover those defects that:

occur following improper, negligent or careless use or storage of the equipment are caused by wrong installation, maintenance or repair performed by non-authorized personnel, or by damage due to transport.

Are not referable to manufacturing defects.

Are caused by the use of non-original fittings and spare parts.

Have been caused by lightning, wrong supply voltage or other force majeure events, not ascribable to the manufacturer.

7.6 Disposal

In compliance with article 13 of Law Decree No. 151 of 25th July 2005 "implementation of the 2002/95/EC, 2002/96/EC and 2003/108/EC Directives concerning the reduction of hazardous materials in electric and electronic devices, and waste disposal"

The crossed bin symbol means that this product must be disposed of separately from other waste and not in household waste after its use.

The User must dispose of this equipment in the special collection centres for electric and electronic waste, as regulated by the local legislation in force.

The proper selective waste collection, followed by recycling, treatment and eco-compatible disposal of the equipment, has a positive impact on the environment and health because it facilitates the re-use and recycling of the materials composing the equipment.

The illegal disposal of the product by the User implies the administrative sanctions provided for by the regulations in force.

Be careful when disposing of the hydraulic oil contained in the equipment, which must be delivered to authorized treatment centres.



7.7 Manufacturer's declaration of conformity

**EC DECLARATION
OF CONFORMITY**

MA-VE International S.R.L.
Strada Genghe di Atto, 105
47892 Acquaviva
Repubblica di San Marino

We declare under our own responsibility that the product
HYDRAULIC LEVELLING SYSTEM
Complies with the following standards:

XXX
XXXX
XXXX

Repubblica di San Marino 12/11/2015

The owner
Marco Santoli

GB



7.8 Warranty certificate

Fill in and send to

MA-VE International S.R.L.
Strada Genghe di Atto, 105
47892 Acquaviva
Repubblica di San Marino

NAME	SURNAME	ADDRESS	CITY
ZIP CODE	PROVINCE	TELEPHONE	E-MAIL
Date of purchase	-----	Retailer's stamp:	



MA-VE INTERNATIONAL s.r.l.
Strada Genghe Di Atto, 105
47892 Acquaviva (RSM)
Tel. 0549/911744 Fax. 0549/99431
e-mail: info@ma-ve.com
web: www.ma-ve.com

MA-VE International reserves the right to make changes without prior notice - Rev.01 of 18-01-16

MA-VE International behält sich das Recht vor, Änderungen ohne Vorankündigung zu machen

MA-VE International si riserva di apportare qualsiasi modifica senza preavviso - Rev.01 del 18-01-16